



Refrigerated Glass Door Merchandisers

Models RS-CN-0145, 0021, 0021-B, 0040-B, 0052, 0052-B, 0080-B

Items 47240, 44527, 44575, 44528, 44496, 44529, 44530

Instruction Manual



Toll Free: 1-800-465-0234

Fax: 905-607-0234

Email: service@omcan.com

www.omcan.com



Table of Contents

Model RS-CN-0145 / Model RS-CN-0021 / Model RS-CN-0021-B
Model RS-CN-0040-B / Model RS-CN-0052 / Model RS-CN-0052-B
Model RS-CN-0080-B

Section	Page
Disclaimer -----	3
General Information -----	4 - 5
Safety and Warranty -----	5 - 6
Technical Specifications -----	7 - 8
Installation -----	8 - 9
Operation -----	9
Maintenance -----	10
Troubleshooting -----	10 - 11
Parts Breakdown -----	12 - 17
Electrical Schematics -----	18 - 22
Warranty Registration -----	23

Disclaimer

OMCAN IS NOT RESPONSIBLE FOR ANY DAMAGES DUE TO WATER LEAKS. WARRANTY FOR WATER LEAKS IS VOID IF THE WICKING PAD IS NOT REPLACED EVERY SIX MONTHS, AND IF THE AMBIENT ROOM TEMPERATURE EXCEEDS 75°F AND 55% RELATIVE HUMIDITY, AND THE APPLIANCE DRAIN IS NOT CONNECTED DIRECTLY TO THE FLOOR DRAIN.

OMCAN N'EST PAS RESPONSABLE DES DOMMAGES DUS AUX FUITES D'EAU. LA GARANTIE POUR LES FUITES D'EAU EST ANNULÉE SI LE TAMPON ABSORBANT N'EST PAS REMPLACÉ TOUS LES SIX MOIS, ET SI LA TEMPÉRATURE AMBIANTE DE LA PIÈCE DÉPASSE 75°F ET 55% D'HUMIDITÉ RELATIVE, ET QUE LE DRAIN DE L'APPAREIL N'EST PAS RACCORDÉ DIRECTEMENT AU DRAIN DE PLANCHER.

OMCAN NO SE HACE RESPONSABLE DE LOS DAÑOS CAUSADOS POR FUGAS DE AGUA. LA GARANTÍA POR FUGAS DE AGUA QUEDA ANULADA SI LA ALMOHADILLA ABSORBENTE NO SE REEMPLAZA CADA SEIS MESES, Y SI LA TEMPERATURA AMBIENTE SUPERA LOS 75°F Y EL 55% DE HUMEDAD RELATIVA, Y EL DESAGÜE DEL APARATO NO ESTÁ CONECTADO DIRECTAMENTE AL DESAGÜE DEL PISO.

General Information

Omcan Manufacturing and Distributing Company Inc., Food Machinery of America, Inc. dba Omcan and Omcan Inc. are not responsible for any harm or injury caused due to any person's improper or negligent use of this equipment. The product shall only be operated by someone over the age of 18, of sound mind, and not under the influence of any drugs or alcohol, who has been trained in the correct operation of this machine, and is wearing authorized, proper safety clothing. Any modification to the machine voids any warranty, and may cause harm to individuals using the machine or in the vicinity of the machine while in operation.

CHECK PACKAGE UPON ARRIVAL

Upon receipt of an Omcan shipment please inspect for external damage. If no damage is evident on the external packaging, open carton to ensure all ordered items are within the box, and there is no concealed damage to the machine. If the package has suffered rough handling, bumps or damage (visible or concealed), please note it on the bill of lading before accepting the delivery and contact Omcan within 24 hours, so we may initiate a claim with the carrier. A detailed report on the extent of the damage caused to the machine must be filled out within three days, from the delivery date shown in the shipping documents. Omcan has no recourse for damaged products that were shipped collect or third party.

Before operating any equipment, always read and familiarize yourself with all operation and safety instructions.

Omcan would like to thank you for purchasing this machine. It's of the utmost importance to save these instructions for future reference. Also save the original box and packaging for shipping the equipment if servicing or returning of the machine is required.

Omcan Fabrication et distribution Compagnie Limité et Food Machinery d'Amérique, dba Omcan et Omcan Inc. ne sont pas responsables de tout dommage ou blessure causé du fait que toute personne ait utilisé cet équipement de façon irrégulière. Le produit ne doit être exploité que par quelqu'un de plus de 18 ans, sain d'esprit, et pas sous l'influence d'une drogue ou d'alcool, qui a été formé pour utiliser cette machine correctement, et est vêtu de vêtements de sécurité appropriés. Toute modification de la machine annule toute garantie, et peut causer un préjudice à des personnes utilisant la machine ou des personnes à proximité de la machine pendant son fonctionnement.

VÉRIFIEZ LE COLIS DÈS RÉCEPTION

Dès réception d'une expédition d'Omcan veuillez inspecter pour dommages externes. Si aucun dommage n'est visible sur l'emballage externe, ouvrez le carton afin de s'assurer que tous les éléments commandés sont dans la boîte, et il n'y a aucun dommage dissimulé à la machine. Si le colis n'a subi aucune mauvaises manipulations, de bosses ou de dommages (visible ou cachée), notez-le sur le bond de livraison avant d'accepter la livraison et contactez Omcan dans les 24 heures qui suivent, pour que nous puissions engager une réclamation auprès du transporteur. Un rapport détaillé sur l'étendue des dommages causés à la machine doit être rempli dans un délai de trois jours, à compter de la date de livraison indiquée dans les documents d'expédition. Omcan n'a aucun droit de recours pour les produits endommagés qui ont été expédiés ou cueillis par un tiers transporteur.

Avant d'utiliser n'importe quel équipement, toujours lire et vous familiariser avec toutes les opérations et les

General Information

consignes de sécurité.

Omcan voudrais vous remercier d'avoir choisi cette machine. Il est primordial de conserver ces instructions pour une référence ultérieure. Également conservez la boîte originale et l'emballage pour l'expédition de l'équipement si l'entretien ou le retour de la machine est nécessaire.

Omcan Empresa De Fabricacion Y Distribucion Inc. Y Maquinaria De Alimentos De America, Inc. dba Omcan y Omcan Inc. no son responsables de ningun daño o perjuicio causado por cualquier persona inadecuada o el uso descuidado de este equipo. El producto solo podra ser operado por una persona mayor de 18 años, en su sano juicio y no bajo alguna influencia de droga o alcohol, y que este ha sido entrenado en el correcto funcionamiento de esta máquina, y ésta usando ropa apropiada y autorizada. Cualquier modificación a la máquina anula la garantía y puede causar daños a las personas usando la máquina mientras esta en el funcionamiento.

REVISE EL PAQUETE A SU LLEGADA

Tras la recepcion de un envio Omcan favor inspeccionar daños externos. Si no hay daños evidentes en el empaque exterior, Habra el carton para asegurarse que todos los articulos solicitados estén dentro de la caja y no encuentre daños ocultos en la máquina. Si el paquete ha sufrido un manejo de poco cuidado, golpes o daños (visible o oculto) por favor anote en la factura antes de aceptar la entrega y contacte Omcan dentro de las 24 horas, de modo que podamos iniciar una reclamación con la compañía. Un informe detallado sobre los daños causados a la máquina debe ser llenado en el plazo de tres días, desde la fecha de entrega que se muestra en los documentos de envío. Omcan no tiene ningun recurso por productos dañados que se enviaron a recoger por terceros.

Antes de utilizar cualquier equipo, siempre lea y familiarizarse con todas las instrucciones de funcionamiento y seguridad.

Omcan le gustaría darle las gracias por la compra de esta máquina. Es de la mayor importancia para salvar estas instrucciones para futuras consultas. Además, guarda la caja original y el embalaje para el envío del equipo si servicio técnico o devolución de la máquina que se requiere.

Safety and Warranty

SAFETY CAUTIONS

1. This unit uses AC110-120V/60Hz power, there should be a 500VA stabilizer if the voltage fluctuation exceed AC99V ~ 132V.
2. The user should hold the plug when the power is on/off, dragging or pulling the power cord is prohibited.
3. Do not remove the power cord or plug.
4. Must use dependent socket and reliable ground wire. Ground wire must not connect with the null line of the gas pipe, warm gas pipe, water pipe and must be single power.

Safety and Warranty

5. Never splash water on the unit directly.
6. Keep away from explosive, hazardous goods such as ether, gas, alcohol, bonding agents, gunpowder etc.
7. Keep away from spray of inflammables such as paints, coating materials etc.
8. After the unit is switched off, it should not be restarted within 5 minutes.
9. Do not leave the power cord under any heavy objects including the unit itself.
10. Do not drill holes or install other objects on the casing.
11. This cooler is not suitable for storage pharmaceutical products.

CAUTION

- The unit is not suitable for storage of blood, pharmaceutical products and biological products.
- Do not place heavy articles on the top of the unit.
- In case of trouble, please ask professional person for service, do not dismantle the unit without prior authority to avoid hazard.

NOTE: THESE UNITS ARE TO BE USED FOR DRINKS ONLY, DO NOT STORE FOOD IN THESE UNITS.

RESIDENTIAL USERS: vendor assumes no liability for parts or labor coverage for component failure or other damages resulting from installation in non-commercial or residential applications. The right is reserved to deny shipment for residential usage; if this occurs, you will be notified as soon as possible.

1 YEAR PARTS AND LABOUR BENCH WARRANTY

Within the warranty period, contact Omcan Inc. at 1-800-465-0234 to schedule a drop off to either an Omcan authorized service depot in the area, or to an Omcan Service warehouse to repair the equipment.

Unauthorized maintenance will void the warranty. Warranty covers electrical and part failures, not improper use.

Please see <https://omcan.com/disclaimer> for complete info.

WARNING:

The packaging components are classified as normal solid urban waste and can therefore be disposed of without difficulty.

In any case, for suitable recycling, we suggest disposing of the products separately (differentiated waste) according to the current norms.

DO NOT DISCARD ANY PACKAGING MATERIALS IN THE ENVIRONMENT!



Technical Specifications

Model	RS-CN-0021-B	RS-CN-0021	RS-CN-0021-B	RS-CN-0040-B
Item Number	47240	44527	44575	44528
Capacity	145 L / 5.12 cu.ft.	21 L / 0.74 cu.ft.		40 L / 1.41 cu.ft.
Temperature Range	0 - 10°C / 32 - 50°F			
Refrigerant	R600A			
Max Ambient Temp Rating	24°C / 75°F			
Defrosting	Yes			
Power	150 W	76 W		
Electrical	110-120V / 60Hz / 1			
Quantity of Shelves	6	1	2	
Shelf Material	Metal		ABS	
Shelf Capacity	33.1 lbs. / 15 kgs.			
Shelf Dimensions	12.6" x 13" 320 x 330mm	10.8" x 9.8" 275 x 250mm	9.8" x 10.2" 250 x 260mm	12" x 10" 305 x 255mm
Interior Dimensions	13.4" x 13.4" x 52.2" 340 x 340 x 1325mm	11" x 10.2" x 14.7" 280 x 260 x 373mm	9.8" x 10.2" x 14.3" 250 x 260 x 363mm	12" x 10" x 17.7" 305 x 255 x 450mm
Net Dimensions (WDH)	16.5" x 17.5" x 74.2" 420 x 445 x 1885mm	16.1" x 13" x 18.5" 410 x 330 x 470mm	13" x 16.3" x 24" 330 x 415 x 610mm	
Packaging Dimensions	19.8" x 20.8" x 77.1" 502 x 529 x 1959mm	19.1" x 16.8" x 21.4" 486 x 426 x 544mm	16.8" x 19.1" x 26.9" 426 x 486 x 684mm	17.8" x 17.6" x 30.6" 451 x 447 x 777mm
Net Weight	110.2 lbs. / 50 kgs.	33.1 lbs. / 15 kgs.	35.3 lbs. / 16 kgs.	44.1 lbs. / 20 kgs.
Packaging Weight	121.3 lbs. / 55 kgs.	36.4 lbs. / 16.5 kgs.	39.7 lbs. / 18 kgs.	48.5 lbs. / 22 kgs.

Technical Specifications

Model	RS-CN-0052	RS-CN-0052-B	RS-CN-0080-B
Item Number	44496	44529	44530
Capacity	52 L / 1.83 cu.ft.		80 L / 2.82 cu.ft.
Temperature Range	0 - 10°C / 32 - 50°F		
Refrigerant	R600A		
Max Ambient Temp Rating	24°C / 75°F		
Defrosting	Yes		
Power	80 W	76 W	92 W
Electrical	110-120V / 60Hz / 1		
Quantity of Shelves	1	3	
Shelf Material	Metal	ABS	
Shelf Capacity	33.1 lbs. / 15 kgs.		
Shelf Dimensions	14.8" x 9.3" / 376 x 235mm	13" x 10.6" / 330 x 270mm	13.8" x 11" / 351 x 279mm
Interior Dimensions	14.5" x 14.8" x 16.2" 368 x 376 x 411mm	13" x 10.6" x 19.7" 330 x 270 x 500mm	13.8" x 11" x 24.8" 351 x 279 x 630mm
Net Dimensions (WDH)	17.1" x 19.1" x 20.1" 435 x 485 x 510mm	16.5" x 18.1" x 31.2" 419 x 460 x 793mm	18.2" x 18.5" x 36.7" 462 x 470 x 932mm
Packaging Dimensions	22.9" x 20.5" x 22" 581 x 521 x 559mm	20.8" x 19.8" x 33.3" 528 x 502 x 846mm	21.2" x 21.3" x 38.8" 539 x 541 x 986mm
Net Weight	43 lbs. / 19.5 kgs.	50.7 lbs. / 23 kgs.	63.9 lbs. / 29 kgs.
Packaging Weight	47.4 lbs. / 21.5 kgs.	55.1 lbs. / 25 kgs.	70.5 lbs. / 32 kgs.

Installation

INSTALLATION AND STORAGE

1. Keep the unit vertical when carrying the unit, the angle to the horizontal line should not be over 50°, otherwise it will damage the compressor and affect normal operation of the unit.
2. The unit should be placed on a solid and firm ground, take away the bottom pack to lower the shock and noise.
3. Leave at least 20 cm of distance between the back of the unit and the wall for ventilation and leave a space with an open angle of 160° for the door.
4. Keep the unit away from heat sources and avoiding direct sunlight.
5. Never place the unit on a location where water can reach or with high moisture. Splashed water and dirt

Installation

should be wiped off in time by using a soft cloth.

6. Do not place the unit in the environment cold enough to be iced.

BEFORE USE

1. Remove the carton and packing foam (including the bottom foam) before using.
2. Clean the unit before using.
3. Adjust the foot to make the unit steady according to the ground condition to lower the shock and noise.
4. After moving the unit, place the unit for 30 minutes before switching it on.
Running: close the door and connect the power, turn on the lamp switch on the control panel, the lamp is on. Half an hour later, the temperature inside the case lower apparently, it indicates the unit on be normally used.
5. After connecting the power, the unit should be kept empty for one hour.

Operation

SETTING AND ADJUSTING THE TEMPERATURE

1. Adjust the storage temperature through the temperature controller located on the back of the case, adjust the temperature according to the ambient temperature and the foodstuff.
2. See the following picture about the knob scale. The temperature adjustable capacity is from "1"- "5", adjust the storage temperature by turning the temperature controller clockwise. The higher of the number shows the lower of the storage temperature. The knob can turn freely but can't turn clockwise from "5" to "1". Factory setting position is on "3".
3. Check if the scale is on an appropriate position before using, frequent adjustment is not appropriate when using. Normally in summer, the ambient temperature is high, anti clockwise turn the knob to "2", while in winter, the ambient temperature is low, clockwise turn the knob to "4".
4. Position "0" represent stop running.

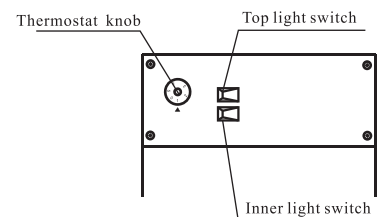
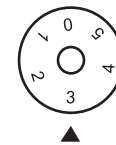

The back side of refrigerator

STORAGE OF PRODUCT

1. Do not put large amount of product into the unit at one time, you should leave some space around the foodstuff to let cold air inside the cabinet counter to flow. Keep bottled articles away from the walls of interior cabinet so as not to freeze it until broken.
2. Do not put warm food into the unit directly until they are cooled under normal temperature, it will facilitate to lower its energy consumption and prolong service life of the compressor.

Maintenance

DISCONNECT THE POWER SUPPLY BEFORE MAINTENANCE FOR THE MACHINE!

1. Keep the door gasket clean, remove it from the door and wash it. Dry and seal it as before. Putting some talcum powder on the magnetic surface would prolong its service life.
2. Bulb replacement: remove the lamp shade, take out the bulb, replace with a new bulb, then mount it again.
3. If there is heavy frost on the evaporator after long usage, take out the stuff inside the case, disconnect the power, the frost will melt automatically, clean up the water and connect the power again.
4. Use a soft cloth and dip some water or soap (non-caustic, neutral detergent is also available) to clean the unit. Dry the unit after cleaning to avoid rust.
5. Do not use organic liquid, boiled water, washing powder or acid stuff to clean the unit. Rinsing the case by water is not allowed, don't use hard brush, steel brush to clean the case.
6. If the unit will not be used for a long time, disconnect the power, clean it by following the above steps, wipe off the water inside the case with a soft cloth.

Troubleshooting

Problems	Possible Causes	Solutions
The units does not work.	Bad connection of plug.	Re-connect the plug to power supply.
Abnormal operation of the compressor or has buzz sound.	The power voltage is out of the rated range.	Disconnect the power supply immediately and reconnect with it after normal voltage. It is necessary to have a voltage stabilizer in case of poor power supply.
Compressor operates too long time and no frost on the surface of inner cabinet.	Refrigeration system is at fault (leakage or blocked).	Send the unit to service department for repair.
There is frost or ice on the walls of the inner cabinet and too low internal temperature, the compressor operates never stop.	Thermostat does not work.	Ask service department for repair.

Troubleshooting

The internal temperature is too high and the compressor operates never stop.	Bad heat dissipation and ventilation of casing, the ambient temperature is too high.	Improve ventilation and lower the ambient temperature.
	Too much warm food was put in at one time.	Take out some food.
	Door open frequently and long time door opening.	Decrease number and time of door opening.
Too high noise.	The unit is not level.	Adjust the adjustable legs.
	The fastener of the unit is loose.	Fasten the loose fastener.
	Pipes are touching the compressor.	Careful separate the touched pipes.
Light is not on.	The light is burned out.	Replace the light.

NORMAL PHENOMENA

1. Sometime hear light sound of water flowing in the unit, this is the sound of refrigerant flowing inside the pipe.
2. The top, and the two sides of the casing will be warm, even too hot.
3. In a humidity place, there is dew on the casing or the door, it can dry by dry cloth.

Parts Breakdown

Model RS-CN-0145 47240

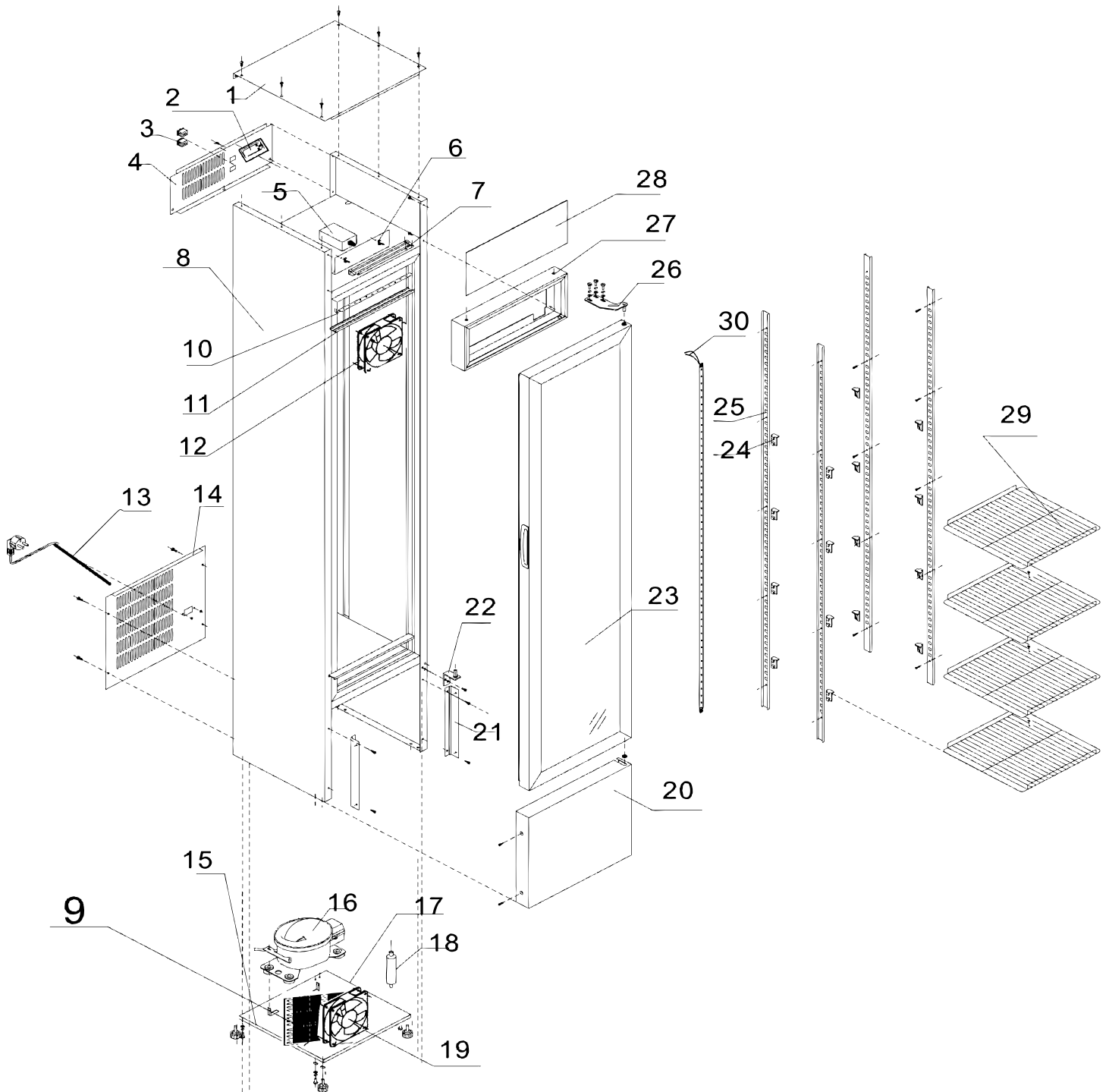

Parts Breakdown

Model RS-CN-0021 44527

Model RS-CN-0052 44496

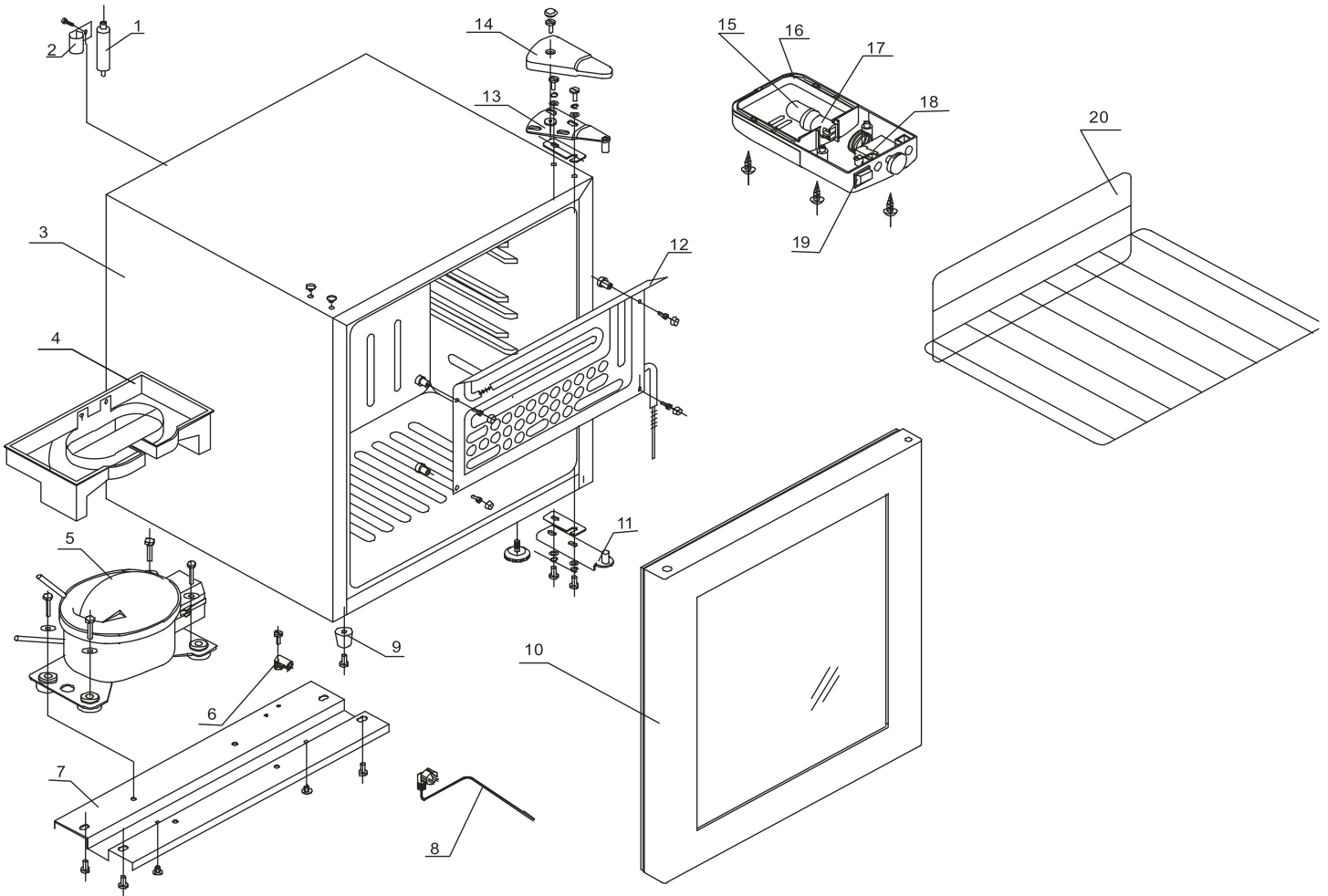

Parts Breakdown

Model RS-CN-0021-B 44575

Model RS-CN-0040-B 44528

Model RS-CN-0052-B 44529

Model RS-CN-0080-B 44530

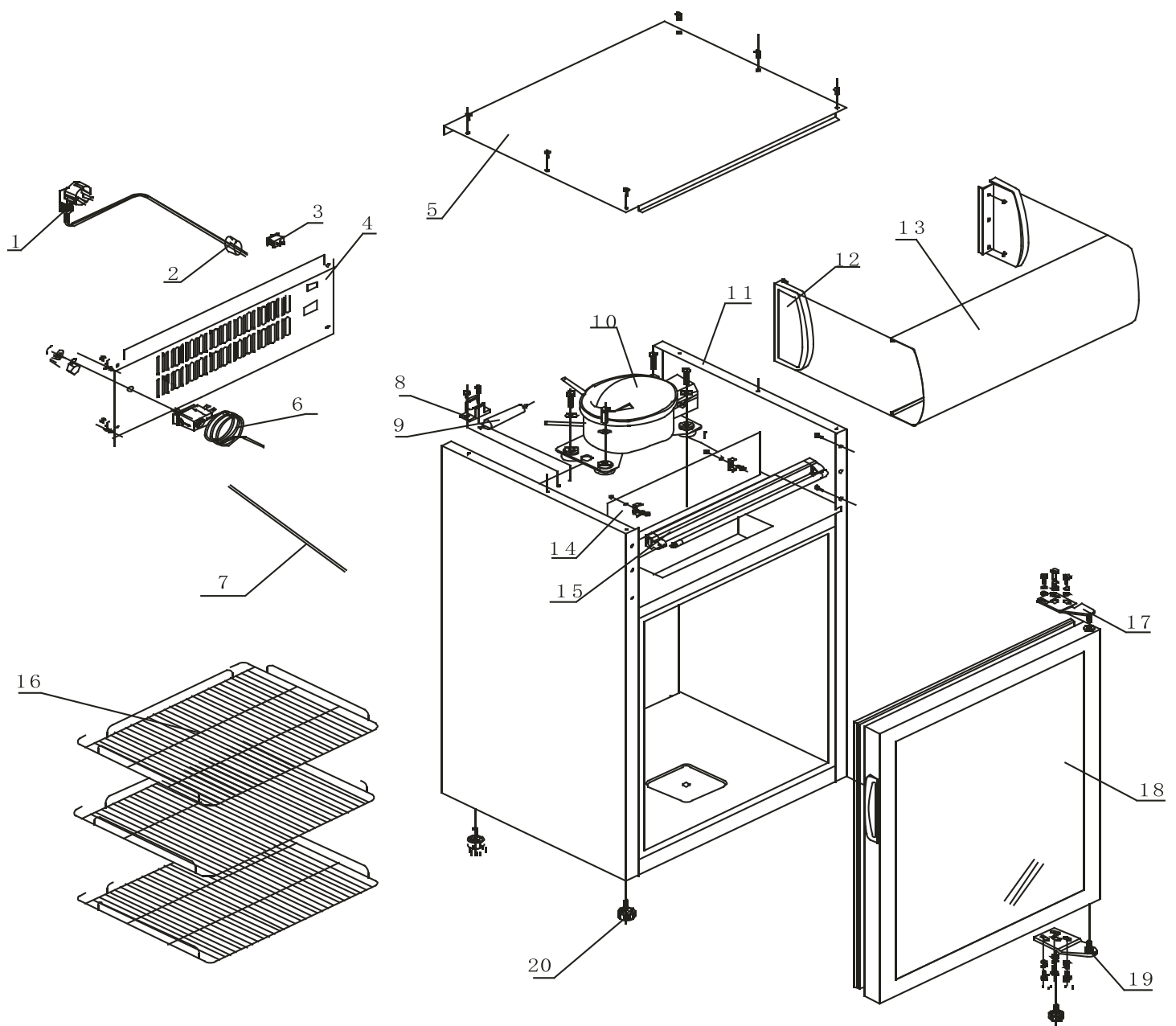



Parts Breakdown

Model RS-CN-0145 47240

Item No.	Description	Position	Item No.	Description	Position	Item No.	Description	Position
AH198	Top Board for 47240	1	AN669	Lampshade for 47240	11	AN672	Connector for Front Bottom Panel for 47240	21
AN666	Digital Temperature Controller for 47240	2	AH220	Inner Fan for 47240	12	AH215	Bottom Hinge for 47240	22
AN667	On/Off Button for 47240	3	AH204	Power Line for 47240	13	AH210	Glass Door for 47240	23
AH201	Back Board for 47240	4	AH205	Compressor Room Cover Board for 47240	14	AH212	Shelf Holder for 47240	24
AH225	Transformer for 47240	5	AN670	Base Foot for 47240	15	AH211	Stand Column for 47240	25
AH202	Lamp Holder for 47240	6	AH206	Compressor QD75Y11G for 47240	16	AH216	Upper Hinge for 47240	26
AH224	Inner Top LED Light for 47240	7	AH207	Compressor Baseboard for 47240	17	AH217	Lightbox Frame for 47240	27
AH203	Body for 47240	8	AH208	Filter Drier for 47240	18	AH218	Lightbox Front Board for 47240	28
AH219	Condenser for 47240	9	AN671	Heat Elimination Fan for 47240	19	AH213	Shelf for 47240	29
AN668	Inner LED Lamp for 47240	10	AH209	Compressor Front Board for 47240	20	AH222	Light on Glass Door for 47240	30

Model RS-CN-0021 44527

Item No.	Description	Position	Item No.	Description	Position	Item No.	Description	Position
AH340	Device for Drying for 44527	1	AH347	Power Line for 44527	8	AH354	Light for 44527	15
AH341	Filter Trestle for 44527	2	AH348	Foot for 44527	9	AH355	Light Trestle for 44527	16
AH342	Case for 44527	3	AH349	Glass Door for 44527	10	AH356	Lamp-Socket for 44527	17
AH343	Water Pan for 44527	4	AH350	Below Hinge for 44527	11	AH357	Thermostat for 44527	18
69130	Compressor UKN35YA for 44527	5	AH351	Evaporator for 44527	12	AH358	Switch for 44527	19
AH345	Line Ball Clip for 44527	6	AH352	Up Hinge for 44527	13	AH359	Shelf for 44527	20
AH346	Compressor Baseplate for 44527	7	AH353	Hinged Cover for 44527	14			

Parts Breakdown

Model RS-CN-0052 44496

Item No.	Description	Position	Item No.	Description	Position	Item No.	Description	Position
AH360	Device for Drying for 44496	1	AH367	Power Line for 44496	8	AH374	Light for 44496	15
AH361	Filter Trestle for 44496	2	AH368	Foot for 44496	9	AH375	Light Trestle for 44496	16
AH362	Case for 44496	3	AH369	Glass Door for 44496	10	AH376	Lamp-Socket for 44496	17
AH363	Water Pan for 44496	4	AH370	Below Hinge for 44496	11	AH377	Thermostat for 44496	18
69130	Compressor UKN35YA for 44496	5	AH371	Evaporator for 44496	12	AH378	Switch for 44496	19
AH365	Line Ball Clip for 44496	6	AH372	Up Hinge for 44496	13	AH379	Shelf for 44496	20
AH366	Compressor Baseplate for 44496	7	AH373	Hinged Cover for 44496	14			

Model RS-CN-0021-B 44575

Item No.	Description	Position	Item No.	Description	Position	Item No.	Description	Position
69121	Power Line for 44575	1	69128	Filter Holder for 44575	8	69135	Lamp for 44575	15
69122	Wire Clip for 44575	2	69129	Dry Filter for 44575	9	69136	Shelf for 44575	16
69123	Switch for 44575	3	69130	Compressor UKN35YA for 44575	10	69137	Top Hinge for 44575	17
69124	Back Shroud for 44575	4	69131	Fridge Body for 44575	11	69138	Glass Door for 44575	18
69125	Top Tray for 44575	5	69132	Light Box Plug for 44575	12	69139	Bottom Hinge for 44575	19
69126	Temperature Control for 44575	6	69133	Light Piece for 44575	13	69140	Base Foot for 44575	20
69127	Internal Connection for 44575	7	69134	Lamp Holder for 44575	14			

Model RS-CN-0040-B 44528

Item No.	Description	Position	Item No.	Description	Position	Item No.	Description	Position
69141	Power Line for 44528	1	69148	Filter Holder for 44528	8	69154	Lamp for 44528	15
69142	Wire Clip for 44528	2	69149	Dry Filter for 44528	9	69155	Shelf for 44528	16
69143	Switch for 44528	3	AI557	Compressor QD43Y11G for 44528	10	69156	Top Hinge for 44528	17
69144	Back Shroud for 44528	4	69150	Fridge Body for 44528	11	69157	Glass Door for 44528	18
69145	Top Tray for 44528	5	69151	Light Box Plug for 44528	12	69158	Bottom Hinge for 44528	19
69146	Temperature Control for 44528	6	69152	Light Piece for 44528	13	69159	Base Foot for 44528	20
69147	Internal Connection for 44528	7	69153	Lamp Holder for 44528	14			

Parts Breakdown

Model RS-CN-0052-B 44529

Item No.	Description	Position	Item No.	Description	Position	Item No.	Description	Position
69160	Power Line for 44529	1	69167	Filter Holder for 44529	8	69173	Lamp for 44529	15
69161	Wire Clip for 44529	2	69168	Dry Filter for 44529	9	69174	Shelf for 44529	16
69162	Switch for 44529	3	AI557	Compressor QD43Y11G for 44529	10	69175	Top Hinge for 44529	17
69163	Back Shroud for 44529	4	69169	Fridge Body for 44529	11	69176	Glass Door for 44529	18
69164	Top Tray for 44529	5	69170	Light Box Plug for 44529	12	69177	Bottom Hinge for 44529	19
69165	Temperature Control for 44529	6	69171	Light Piece for 44529	13	69178	Base Foot for 44529	20
69166	Internal Connection for 44529	7	69172	Lamp Holder for 44529	14			

Model RS-CN-0080-B 44530

Item No.	Description	Position	Item No.	Description	Position	Item No.	Description	Position
69179	Power Line for 44530	1	69186	Filter Holder for 44530	8	69192	Lamp for 44530	15
69180	Wire Clip for 44530	2	69187	Dry Filter for 44530	9	69193	Shelf for 44530	16
69181	Switch for 44530	3	AI557	Compressor QD43Y11G for 44530	10	69194	Top Hinge for 44530	17
69182	Back Shroud for 44530	4	69188	Fridge Body for 44530	11	69195	Glass Door for 44530	18
69183	Top Tray for 44530	5	69189	Light Box Plug for 44530	12	69196	Bottom Hinge for 44530	19
69184	Temperature Control for 44530	6	69190	Light Piece for 44530	13	69197	Base Foot for 44530	20
69185	Internal Connection for 44530	7	69191	Lamp Holder for 44530	14			

Electrical Schematics

Model RS-CN-0145 47240

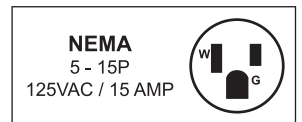
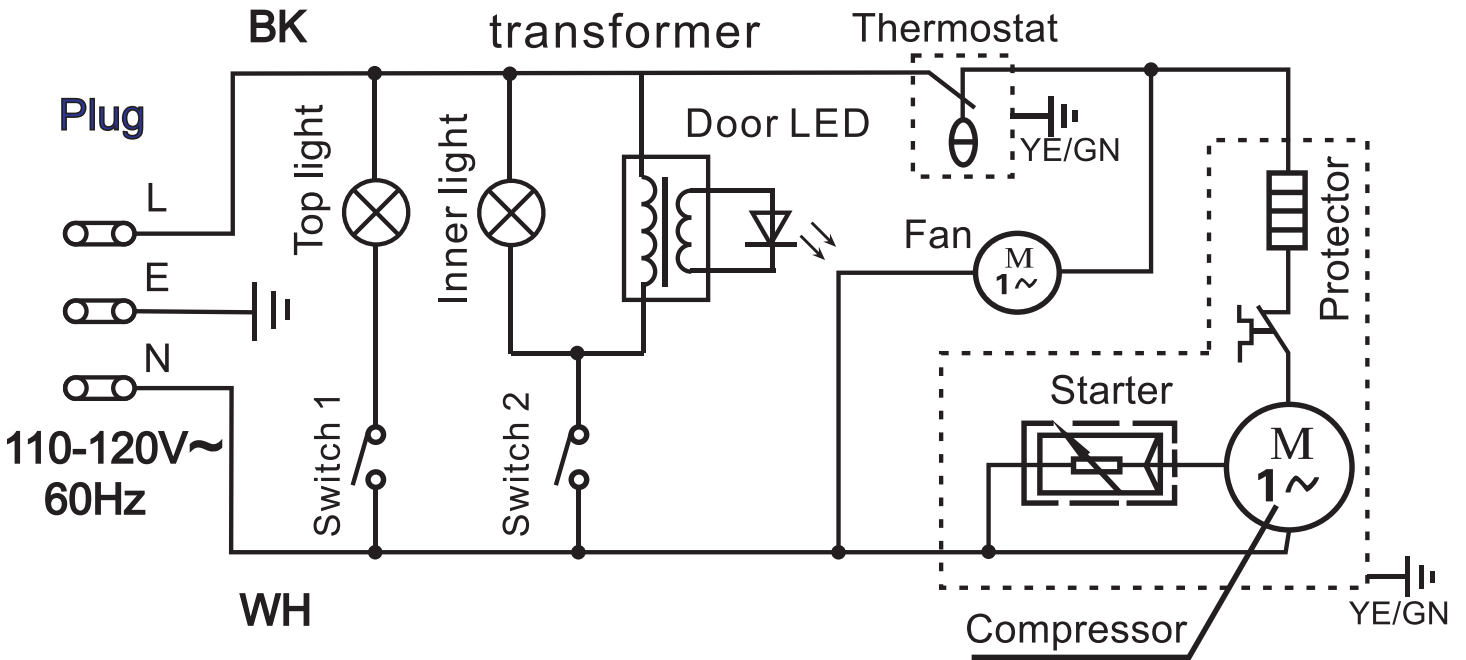

Electrical Schematics

Model RS-CN-0021 44527

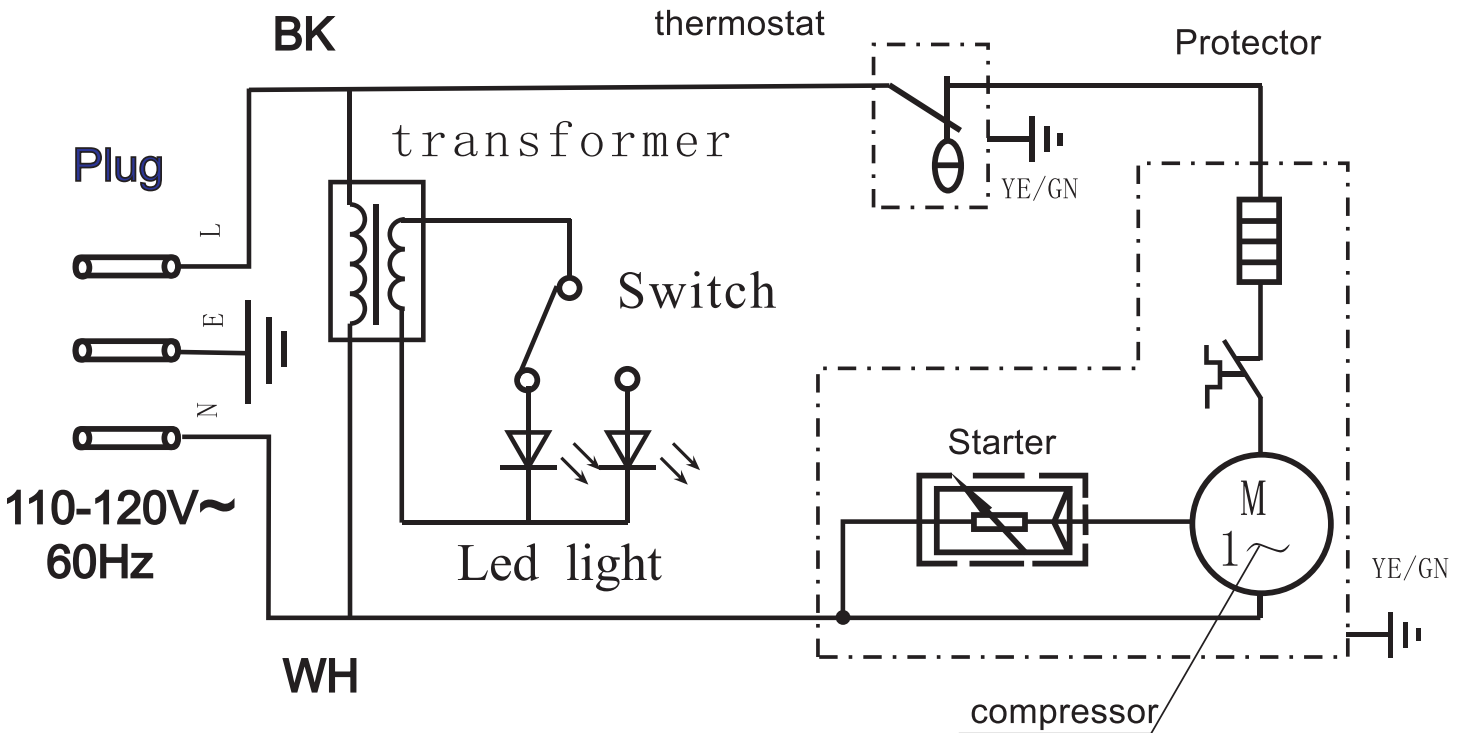

NEMA
5 - 15P
125VAC / 15 AMP

Electrical Schematics

Model RS-CN-0021-B 44575

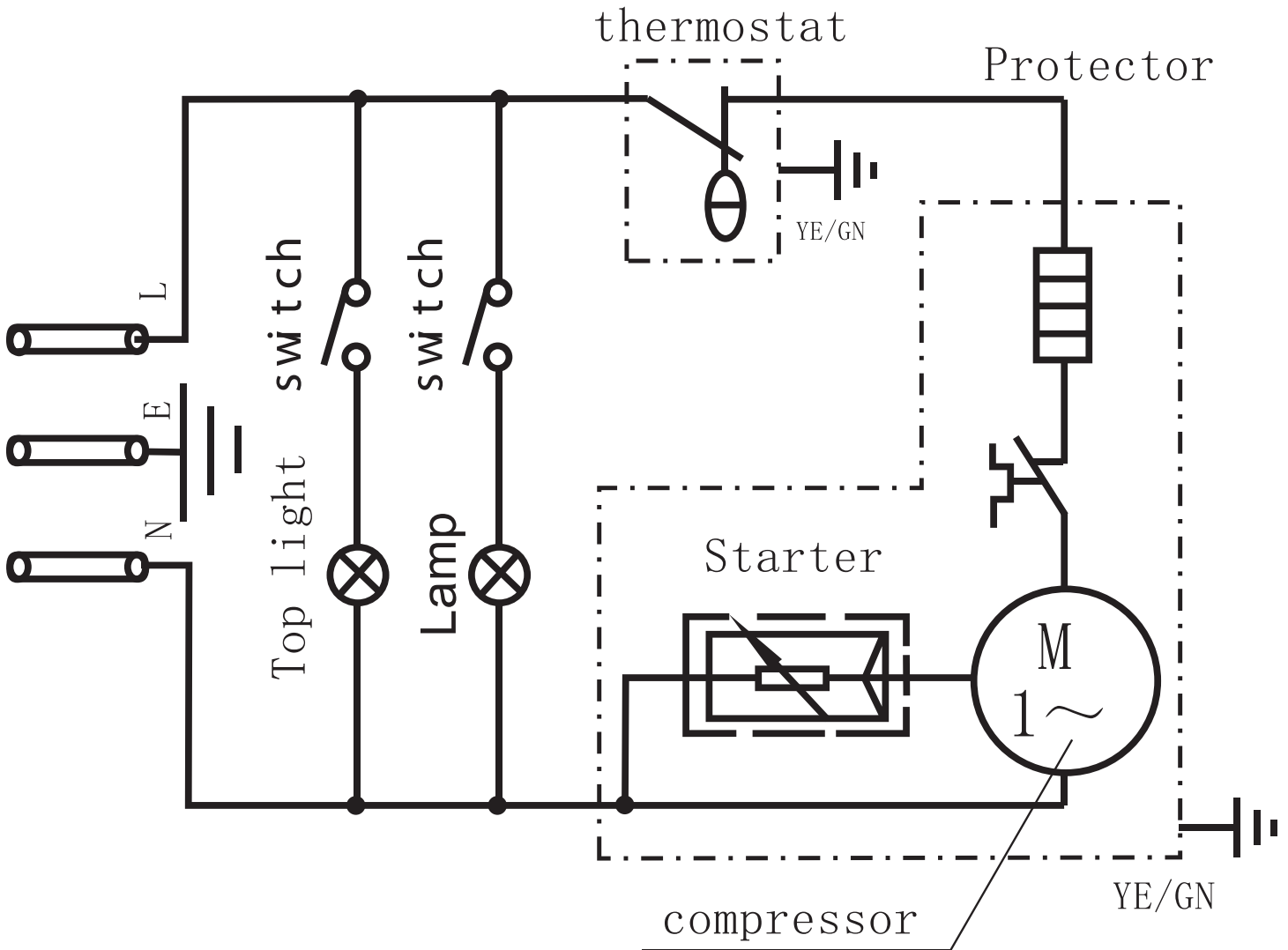

NEMA
5 - 15P
125VAC / 15 AMP

Electrical Schematics

Model RS-CN-0040-B 44528

Model RS-CN-0052-B 44529

Model RS-CN-0080-B 44530

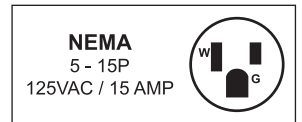
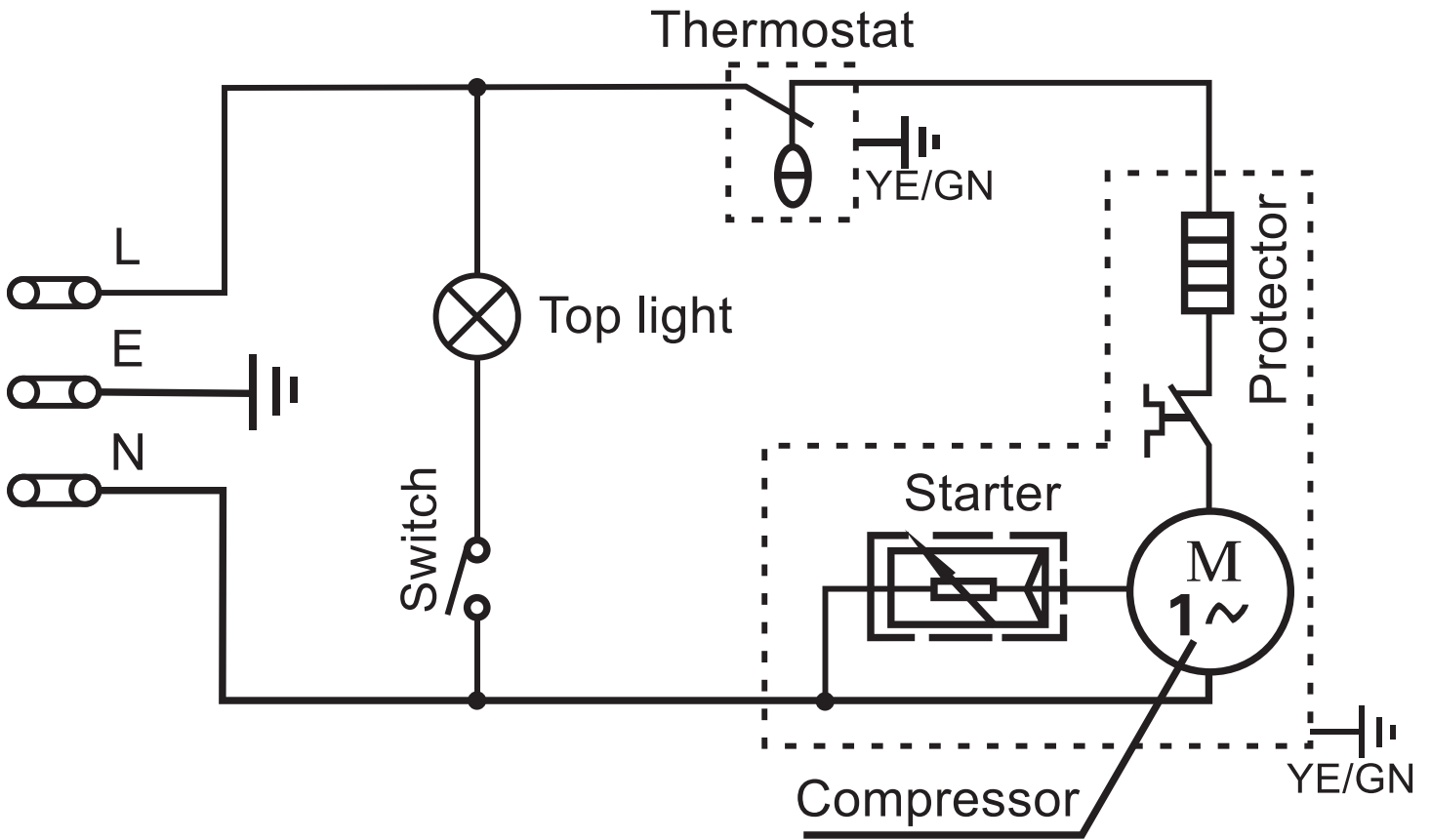

Electrical Schematics

Model RS-CN-0052 44496

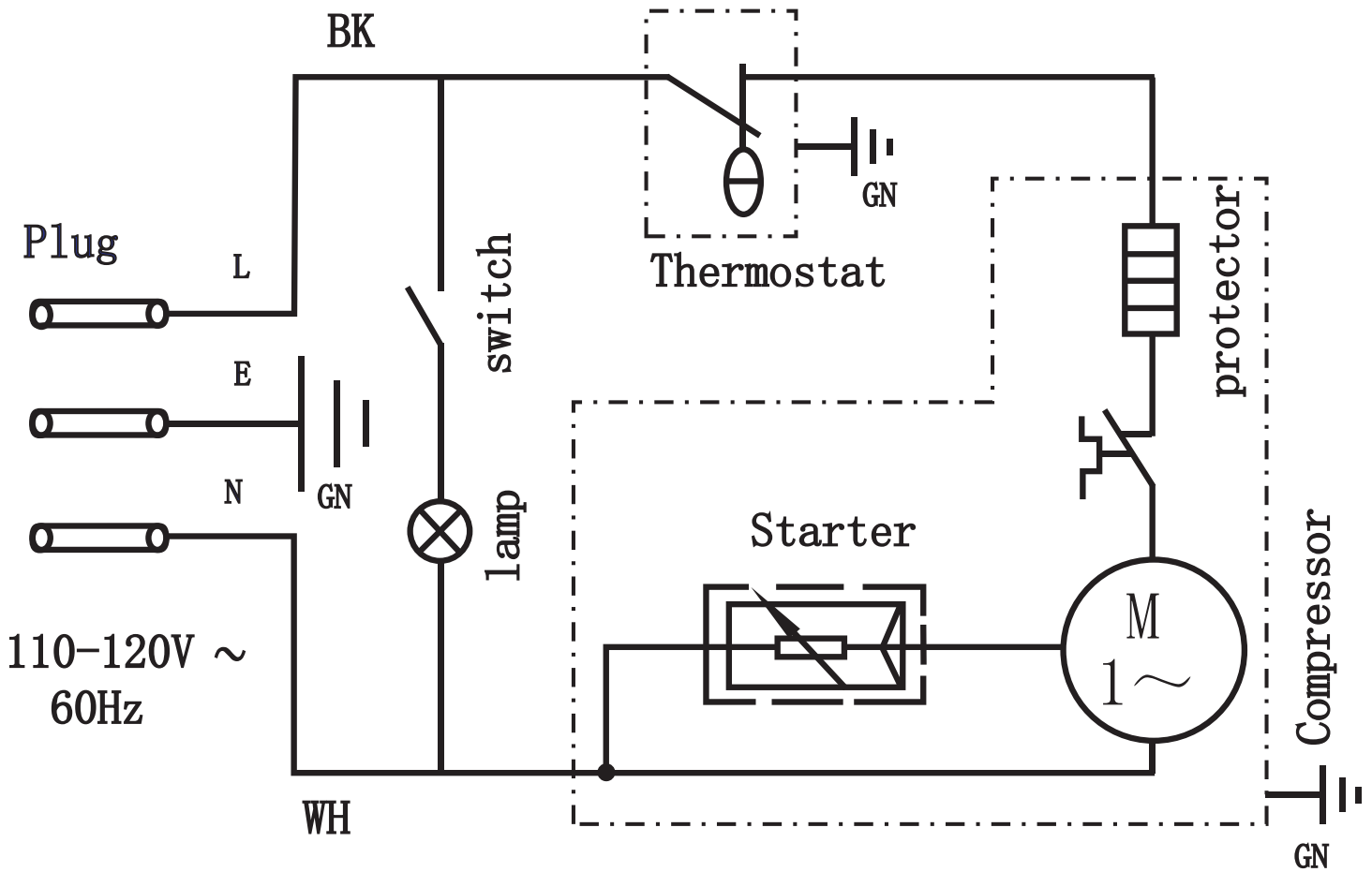

NEMA
 5 - 15P
 125VAC / 15 AMP



Warranty Registration

Thank you for purchasing an Omcan product. To register your warranty for this product, complete the information below, tear off the card at the perforation and then send to the address specified below. You can also register online by visiting:

Merci d'avoir acheté un produit Omcan. Pour enregistrer votre garantie pour ce produit, complétez les informations ci-dessous, détachez la carte au niveau de la perforation, puis l'envoyer à l'adresse spécifiée ci-dessous. Vous pouvez également vous inscrire en ligne en visitant:

Gracias por comprar un producto Omcan usted. Para registrar su garantía para este producto, complete la información a continuación, cortar la tarjeta en la perforación y luego enviarlo a la dirección indicada a continuación. También puede registrarse en línea en:

<https://omcan.com/warranty-registration/>

For mailing in Canada

Pour postale au Canada

Por correo en Canadá

For mailing in the US

Pour diffusion aux États-Unis

Por correo en los EE.UU.

OMCAN

PRODUCT WARRANTY REGISTRATION

3115 Pepper Mill Court,
Mississauga, Ontario
Canada, L5L 4X5

OMCAN

PRODUCT WARRANTY REGISTRATION

4450 Witmer Industrial Estates, Unit 4,
Niagara Falls, New York
USA, 14305

or email to: service@omcan.com



Purchaser's Information

Name: _____

Company Name: _____

Address: _____

Telephone: _____

City: _____ Province or State: _____ Postal or Zip: _____

Email Address: _____

Country: _____

Type of Company:

Restaurant Bakery Deli

Butcher Supermarket Caterer

Institution (*specify*): _____

Other (*specify*): _____

Dealer from which Purchased: _____

Dealer City: _____ Dealer Province or State: _____

Invoice: _____

Model Name: _____ Model Number: _____

Serial Number: _____

Machine Description: _____

Date of Purchase (MM/DD/YYYY): _____

Date of Installation (MM/DD/YYYY): _____

Would you like to extend the warranty? Yes No

Thank you for choosing Omcan | Merci d'avoir choisi Omcan | Gracias por elegir Omcan



Since 1951 Omcan has grown to become a leading distributor of equipment and supplies to the North American food service industry. Our success over these many years can be attributed to our commitment to strengthen and develop new and existing relationships with our valued customers and manufacturers. Today with partners in North America, Europe, Asia and South America, we continually work to improve and grow the company. We strive to offer customers exceptional value through our qualified local sales and service representatives who provide convenient access to over 6,500 globally sourced products.

Depuis 1951 Omcan a grandi pour devenir un des "leaders" de la distribution des équipements et matériel pour l'industrie des services alimentaires en Amérique du Nord. Notre succès au cours de ces nombreuses années peut être attribué à notre engagement à renforcer et à développer de nouvelles et existantes relations avec nos clients et les fabricants de valeur. Aujourd'hui avec des partenaires en Amérique du Nord, Europe, Asie et Amérique du Sud, nous travaillons continuellement à améliorer et développer l'entreprise. Nous nous efforçons d'offrir à nos clients une valeur exceptionnelle grâce à nos ventes locales qualifiées et des représentants de service qui offrent un accès facile à plus de 6500 produits provenant du monde entier.

Desde 1951 Omcan ha crecido hasta convertirse en un líder en la distribución de equipos y suministros de alimentos en América del Norte industria de servicios. Nuestro éxito en estos años se puede atribuir a nuestro compromiso de fortalecer y desarrollar nuevas relaciones existentes con nuestros valiosos clientes y fabricantes. Hoy con socios de América del Norte, Europa, Asia y América del Sur, que trabajan continuamente para mejorar y crecer la empresa. Nos esforzamos por ofrecer a nuestros clientes valor excepcional a través de nuestro local de ventas y representantes de los servicios que proporcionan un fácil acceso a más de 6,500 productos con origen a nivel mundial.

